

Transition Module

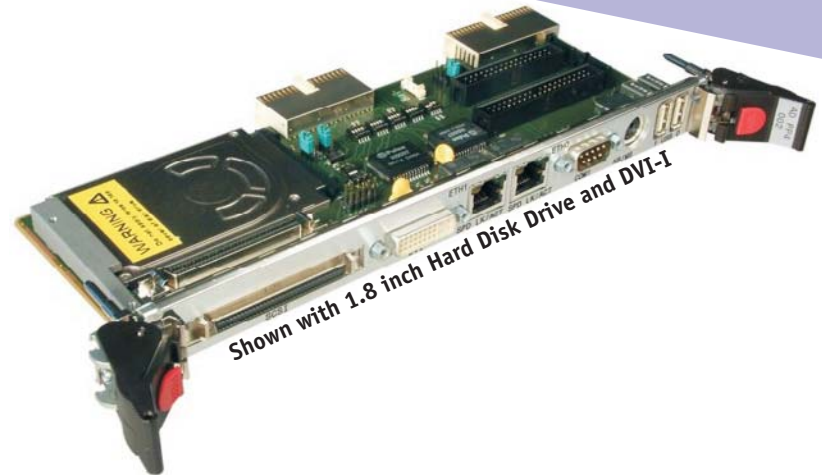

APPLICATIONS

The AD PP4/002-U is designed to be used with various Concurrent Technologies CompactPCI® Slot Controllers, for example, the PP 300/02x-U and PP 302/02x-U. The Transition Module mounts in the rear transition area of the CompactPCI backplane and provides very simple

access to the majority of the I/O functions provided by the processor board. Many I/O functions are provided on the Transition Module's own front panel as well as from headers mounted on the Module.

HIGHLIGHTS

- Transition Module for rear I/O:
 - 80mm depth as per CompactPCI specification
 - single slot
- Interfaces to CompactPCI via J3 and J5
- Dual 10/100/1000Mbps Ethernet via RJ45 connectors on Transition Module's front panel
- Floppy Disk interface via a 34-way header
- EIDE interface via 40-way header and either CompactFlash™ connector or 1.8 inch hard disk drive fitted:
 - supports up to Ultra-DMA 100
- 2 x Serial ATA150 interfaces via onboard header
 - transfer rates up to 150Mbytes/s
- PC speaker via 5-way header
- General Purpose I/O interface via 5-way header
- 2 x USB interfaces via USB connector on Transition Module's front panel and 4-way header
- Digital or analog graphics interface
- COM1 port via 9-way D-type connector on Transition Module's front panel
- COM2 Port via 10-way header or 9-way D-type connector
- System fan monitor via 3-way header
- PS/2 keyboard and mouse interfaces via circular mini DIN connector on Transition Module's front panel
- Ultra-2 Wide SCSI via 68-way header and connector on Transition Module's front panel
- Extended temperature version available:
 - -25°C to +70°C (E-Series)
 - -40°C to +85°C (K-Series, includes humidity sealant)
 - CompactFlash version only

Ethernet Interface

- two channels
- supports 10BaseT, 100BaseTx and 1000BaseT for UTP CAT5 via RJ45 connectors on front panel
- signaling can be routed to transition module's front panel or PICMG® 2.16 Packet Switching Backplane using the onboard switches

EIDE Interface

- supports up to Ultra-DMA 100 speeds via 40-way header
- connectors for either:-
 - 1 x CompactFlash (N, E, K-Series)
 - 1.8 inch Hard Disk Drive fitted (N-Series)

Serial ATA150

- 2 x SATA150 interfaces via onboard header:-
 - transfer rates up to 150Mbytes/s

SCSI

- 68-way high density D-Type on front panel
- 68-way high density vertical D-Type connector on-board
- supports modes up to Ultra-2 Wide SCSI

Floppy Disk Interface

- via 34-way header on board

USB Interfaces

- both accessed via USB connectors and one also via 4-way header

Serial Interface

- 9-way D-type connector for COM1
- 10-way header for COM2
- optional 9-way D-type connector for COM2 (replaces DVI-I connector)

Graphics Interface

- supports an optional DVI-I connector:-
 - supports an analog VGA (DVI-A) interface for driving CRT displays
 - supports a DVI-D interface for driving TFT flat panels
 - connector on the front panel
- not available when COM2 9-way D-type connector fitted

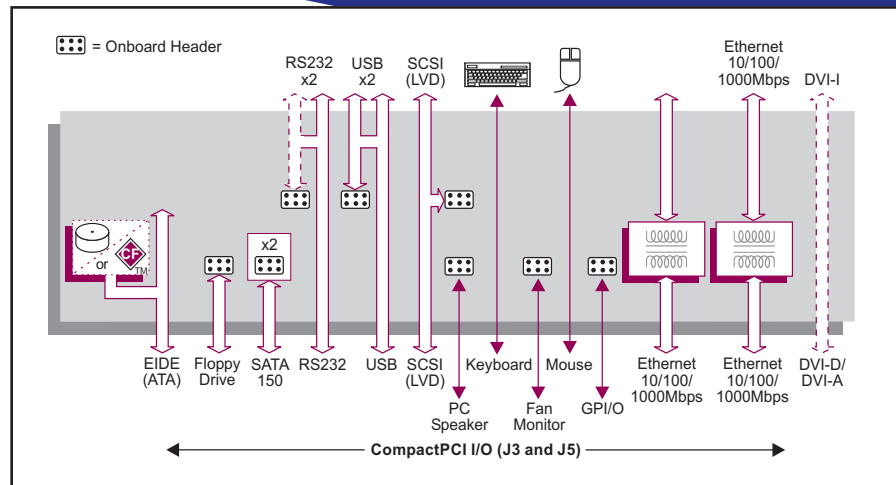

Other Interfaces

- PC speaker via 5-way header
- General Purpose I/O interface via 5-way header
- keyboard and mouse via a single circular mini DIN connector
- system fan monitor via 3-way header

Environmental Specification

- operating temperatures:-
 - 0°C to +55°C (N-Series)
 - -25°C to +70°C (E-Series, CompactFlash)
 - -40°C to +85°C (K-Series, CompactFlash)
- 10% to 90% Relative Humidity, non-condensing (operating):-
 - K-Series includes humidity sealant
- -40°C to +85°C (storage)
- 10% to 90% Relative Humidity, non-condensing (storage)

Electrical Specification

- all voltages to be within ±5%
- +5V@0.2 A - quiescent current;
- +3.3V@0.09 A; +12V@0.0 A; -12V@0.0 A

Mechanical Specification

- 6U form-factor:- 9.2" x 3.2" (233.35mm x 80 mm)
- single-slot: 0.8" (20.3mm)
- connectors: IEC-1076-4-101 for J3 and J5
- shock:
 - 20g, 11ms, ½ sine (operating);
 - 30g, 11ms, ½ sine (non-operating)
- vibration:
 - 5Hz-2000Hz at 2g, 0.38mm peak displacement (operating);
 - 5Hz-2000Hz at 5g, 0.76mm peak displacement (non-operating)

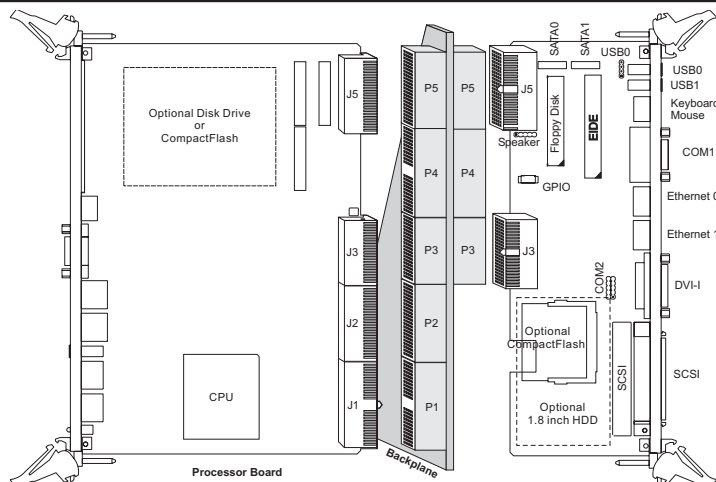

ORDERING INFORMATION

Order Number Product Description (Hardware)

Order Number	Product Description (Hardware)
AD PP4/002-10U	Transition Module with COM2 9-way D-type connector plus CompactFlash connector
AD PP4/002-11U	Transition Module with COM2 9-way D-type connector plus 1.8 inch Hard Disk Drive
AD PP4/002-20U	Transition Module with DVI-I connector plus CompactFlash connector
AD PP4/002-21U	Transition Module with DVI-I connector plus 1.8 inch Hard Disk Drive

For extended temperature, E or K-Series, please contact your local sales office