

Intel® Core™ i7 Processor (32nm) 3U Single Board Computer Rugged Conduction-Cooled

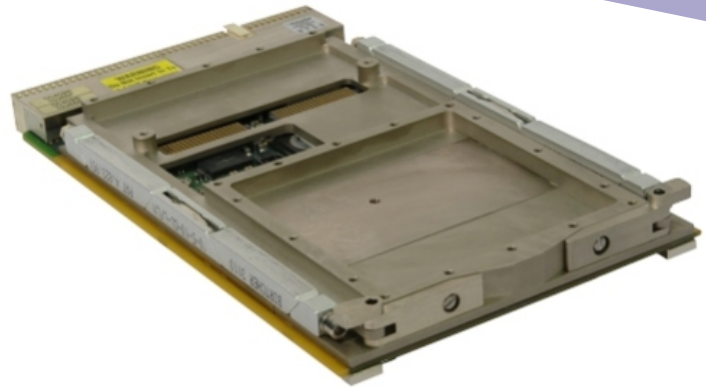

APPLICATIONS

The TP 702/38x-RC is a PC-compatible high performance, high functionality 3U CompactPCI®, ruggedized conduction-cooled board supporting the Intel® Core™ i7 processor (32nm process technology) up to 2.0 GHz, the Mobile Intel® QM57 Express chipset and up to 8 Gbytes of DDR3-1066 ECC SDRAM. This single slot board features a variety of interfaces including dual Serial ATA150, dual Gigabit Ethernet, RS-232/422 and USB. The TP 702/38x-RC is capable of operating with card edge temperatures ranging from -40°C to +85°C

where it is suitable for a range of demanding applications within the defense, industrial control, telecomms, telemetry, scientific and aerospace markets. The TP 702/38x-RC is rear I/O plug compatible with the commercial and the ruggedized air-cooled versions. The board is plug compatible with the popular TP 402/35x-RC family. To simplify the board's integration many popular industry standard operating systems are supported.

HIGHLIGHTS

- Ruggedized 3U single board computer:
 - conduction-cooled to ANSI/VITA 30.1-2002
 - -40°C to +85°C operating temperature (at card edge)
 - conformally coated
- 2.0 GHz or 1.33 GHz Intel® Core™ i7 processor:
 - dual-core processor
 - 1066MHz DRAM Bus (800 MHz for 1.33 GHz processor)
 - 4 Mbytes shared last level cache
 - Intel® Hyper-Threading Technology
 - Intel® Turbo Boost technology
 - Intel® 64 Technology (64-bit computing support)
- Up to 8 Gbytes of dual channel DDR3-1066 ECC SDRAM
- 2 x 10/100/1000Mbps Ethernet interfaces accessed via J2
- 5 x Serial ATA channels:
 - 2 x SATA150 channels accessed via J2
 - 1 x SATA300 channel for optional on-board Flash Drive
 - 2 x SATA300 channels routed to optional Dual Flash Drives
- 2 x serial channel interfaces accessed via J2
- 2 x USB 2.0 interfaces accessed via J2
- Option for analog graphics or XMC I/O via J2
- Watchdog and long duration timer
- CompactPCI controller:
 - operates in the system slot or in a peripheral slot
 - 32-bit at 33/66 MHz CompactPCI interface
- Option to bypass CompactPCI bus (Satellite Mode)
- Optional Built-In Test (BIT) support:
 - Power-on BIT, Initiated BIT, Continuous BIT
- Air-cooled versions (N, E, K-Series and RA-Series):
 - N: 0°C to +55°C, commercial, non-ruggedized
 - E: -25°C to +75°C, extended, non-ruggedized
 - K: -40°C to +85°C, humidity-sealed, non-ruggedized
 - RA: -40°C to +75°C, conformally coated, ruggedized
- Support for Linux®, Windows® 7, Windows® Embedded Standard 7, Windows® XP, Windows® XP Embedded, Windows® Server 2003, Windows® Server 2008, QNX®, Solaris® and VxWorks®

Ruggedized Single Board Computer

- 3U CompactPCI® SBC utilizing Intel® Core™ i7 processor:-
 - conduction-cooled to ANSI/VITA 30.1-2002
 - conformally coated
- for ruggedized and commercial air-cooled versions - see separate datasheets:-
 - rear plug compatible
 - ruggedized: TP 702/38x-RA
 - air-cooled: TP 702/38x

Central Processor

- 2.0 GHz Intel® Core™ i7-620LE processor or 1.33 GHz Intel® Core™ i7-660UE processor
- common processor features are:-
 - dual-core processor
 - 4 Mbytes shared last level cache
 - Intel® Hyper-Threading Technology
 - Intel® 64 Technology (64-bit computing)
 - Intel® Turbo Boost technology
- processor to DRAM memory, bus speed:-
 - 620LE - 1066MHz; 660UE - 800MHz
- Intel Turbo Boost technology allows faster graphics engine speed depending on the CPU load
- utilizes Intel® Platform Controller Hub (PCH):-
 - Mobile Intel® QM57 Express chipset

DRAM

- up to 8 Gbytes DDR3-1066 ECC SDRAM:-
 - up to 8 Gbytes soldered on-board
 - single bit error correction
 - dual channel architecture
- accessible from processor or CompactPCI® bus

Mass Storage Interfaces

- 2 x SATA150 channels accessible via J2
- 1 x SATA300 channel routed to an optional Flash Drive Module (AD 230/00x):-
 - single Flash Drive
 - mounts onboard underneath the XMC site
 - Flash drive write protect signal from backplane
- 2 x SATA300 channels to an alternative optional Flash Drive Module (AD 250/00x):-
 - option for one or two Flash Drives
 - uses the XMC site connectors
 - Flash drive write protect switch on module

Ethernet Interfaces

- 2 x channels supporting:-
 - 10 Base-T, 100 Base-TX, 1000 Base-T
 - implemented by an Intel® 82577 and an Intel® 82574L, via 2 x1 PCI Express® ports
 - both channels accessed via J2

XMC Interface

- 1 x XMC site, all in a single 4HP slot:-
 - XMC (Switched Mezzanine Card) interface via a x4 PCI Express switch (with DMA support)
 - optional rear panel I/O via J2
 - not available with Flash Drive Module fitted (AD 250/00x)

Graphics Interface

- optional analog graphics accessed via J2:-
 - integrated chipset graphics controller
- resolutions up to 1920 x 1200 @ 16M colors
- support for OpenGL 2.0, Windows® and Linux®

Serial Interfaces

- 2 serial interfaces accessible via J2
- 1 x RS-232 interface supporting Tx and Rx
- 1 x RS-232 interface supporting Tx, Rx, RI, CTS, RTS, DSR, DTR and DCD
- or 1 x RS-422/RS-485 supporting Tx and Rx
- 16550 compatible UARTs

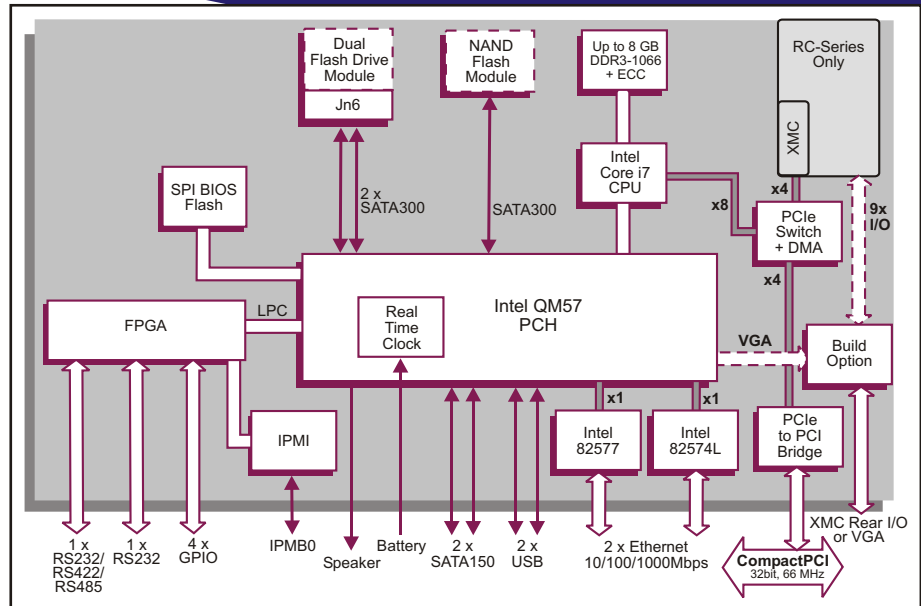

Other Peripheral Interfaces

- PC-compatible Real Time Clock
- long duration timer and watchdog timer
- option for legacy speaker interface via J2
- 2 x USB 2.0 interfaces, both accessed via J2
- external battery supply for RTC and BIOS data
- 4 x GPIO signals via J2
- CPU temperature monitor; voltages monitor; all accessible via IPMI

Flash EPROM

- 8 Mbytes of BIOS Flash EPROM

Firmware Support

- UEFI-compliant BIOS with legacy mode support
- comprehensive Power-On Self-Test (POST)
- LAN boot firmware included

Software Support

- support for Linux®, Windows® 7, Windows® Embedded Standard 7, Windows® XP, Windows® XP Embedded, Windows® Server 2003, Windows® Server 2008, QNX®, Solaris® and VxWorks®

Optional Built-In Test (BIT) Support

- Power-on BIT (PBIT)
- Initiated BIT (IBIT)
- Continuous BIT (CBIT)

CompactPCI Interface

- universal signaling support, compliant with PICMG® 2.0 R3.0; 3.3V or 5V signaling levels
- 33/66 MHz; 32-bit interface accessed via J1
- PCI Express link from processor via PCIe-PCI bridge for off-board accesses:-
 - DMA hardware support included in switch
- operates as a System Slot controller (supporting up to 7 peripheral slots) or operates in a Peripheral Slot:-
 - supports hot-swapping peripheral boards
 - PICMG 2.1 R2.0 Hot Swap Specification
- option to disable CompactPCI® interface (Satellite Mode):-
 - board can be hot swapped

PMI

- PICMG 2.9 R1.0 (System Management Spec.):-
 - implements the IPMB0 interface
- on-board Baseboard Management Controller
- supports 8 Kbytes of non-volatile memory

Safety

- PCB (PWB) manufactured with flammability rating of 94V-0

Electrical Specification

- +5V @ 3.1A (typical 2.0 GHz with 2 Gbytes DRAM)
- +3.3V @ 5.4A
- voltages +5%/-3%
- +12V and -12V not required

Environmental Specification

- operating temperature (at card edge):-
 - VITA 47 Class CC4, -40°C to +85°C
 - conduction-cooled
- storage temperature:-
 - VITA 47 Class C4, -55°C to +105°C
- operating altitude:-
 - -1,000 to 50,000 feet (-305 to 15,240 meters)
- 5% to 95% Relative Humidity, non condensing (operating/storage)

Mechanical Specification

- 3U form-factor: 3.9-inches x 6.3-inches (100mm x 160mm)
- single slot
- connectors: IEC-1076-4-101 for J1-J2
- operating mechanical:-
 - shock - VITA 47 Class OS2, 40g
 - random vibration - VITA 47 Class V3, 0.1g²/Hz

I/O Compatible with the TP 402/35x-RC

- rear I/O compatible with the popular TP 402/35x-RC

ORDERING INFORMATION

Order Number	Product Description (Hardware)
TP 702/380-xyRC	1.33 GHz Intel® Core™ i7-660UE processor
TP 702/382-xyRC	2.0 GHz Intel® Core™ i7-620LE processor

For the order number suffix (xy) options please contact your local sales office:
 where x = I/O
 x - rear I/O configurations
 where y = SDRAM size
 y - up to 8 Gbytes SDRAM

For commercial or ruggedized air-cooled boards, please contact your local sales office.

All companies and product names are trademarks of their respective organizations. Specification subject to change; E and OE. RoHS 2002/95/EC compliant.