

## Intel® Core™ i7 Processor Dual PMC/XMC Embedded Controller



### APPLICATIONS

The VR 737/08x is a PC-compatible, high performance, high functionality 6U VPX processor board based on the Intel® Core™ i7 processor up to 2.53 GHz (32 nm process technology), the Mobile Intel® QM57 Express chipset and up to 8 Gbytes of DDR3-1066 ECC SDRAM. This single slot board features 2 PMC/XMC sites and a variety of interfaces including an option for an on-board 2.5-inch storage drive and CompactFlash™. The VR 737/08x is an

air-cooled commercial VPX board and is suitable for a range of applications within industrial control, transport, aerospace, security and defense applications. For rugged applications two VPX-REDI versions are available, the VR 737/08x-RCS is a VPX-REDI Type 1 Two-Level Maintenance conduction-cooled board and the VR 737/08-RCT is VPX-REDI Type 2. For all board versions, to simplify integration, many operating systems are supported.

### HIGHLIGHTS

- 6U VPX (VITA 46.0) N-Series single board computer:
  - air-cooled, 0°C to +55°C operating temperature
  - use in commercial (non-rugged) applications
  - 6U VPX 0.8 inch slot
  - optional rear transition module available
- I/O interfaces compatible with several OpenVPX profiles
- 2.53 GHz, 2.0 GHz or 1.33 GHz Intel® Core™ i7 processor:
  - dual-core processor
- Up to 8 Gbytes dual channel DDR3-1066 SDRAM
- Configurable PCI Express® (PCIe) data plane fabric interface (VITA 46.4) supports :
  - four x8 or eight x4 PCI Express ports, with DMA
  - support for Gen 1 and Gen 2
  - compatible with OpenVPX™ (VITA 65) module profiles
  - supports four transparent/non-transparent links
- Configurable control plane fabric interface (VITA 46.6) supports:
  - 2 x Gigabit Ethernet and 2 x 1000Base-BX interfaces via P4
- 1 x Gigabit Ethernet port via front panel
- 2 x PMC/XMC module interfaces:
  - 32/64-bit, 33/66/100 MHz PCI/PCI-X™
  - 2 x XMC module interfaces (x8 PCI Express®)
  - rear I/O options via Pn4 or Pn6 connector
- 2 x SATA300 interfaces
- 8 x GPI, 8 x GPIO, 5 x USB 2.0 and 6 x serial interfaces
- Dual digital and analog graphics interface
- Stereo audio
- Watchdog and long duration timers
- Optional Built-In Test (BIT) supports:
  - Power-on BIT, Initiated BIT, Continuous BIT
- Ruggedized conduction-cooled versions (RCx-Series):
  - conduction-cooled to VITA 48.2
  - -40°C to +85°C (at card edge), conformally coated
- Support for Linux®, Windows® 7, Windows® Embedded Standard 7, Windows® XP, Windows® XP Embedded, Windows® Server 2008 , Windows® Server 2003, QNX® , VxWorks® , Solaris™ and LynxOS®

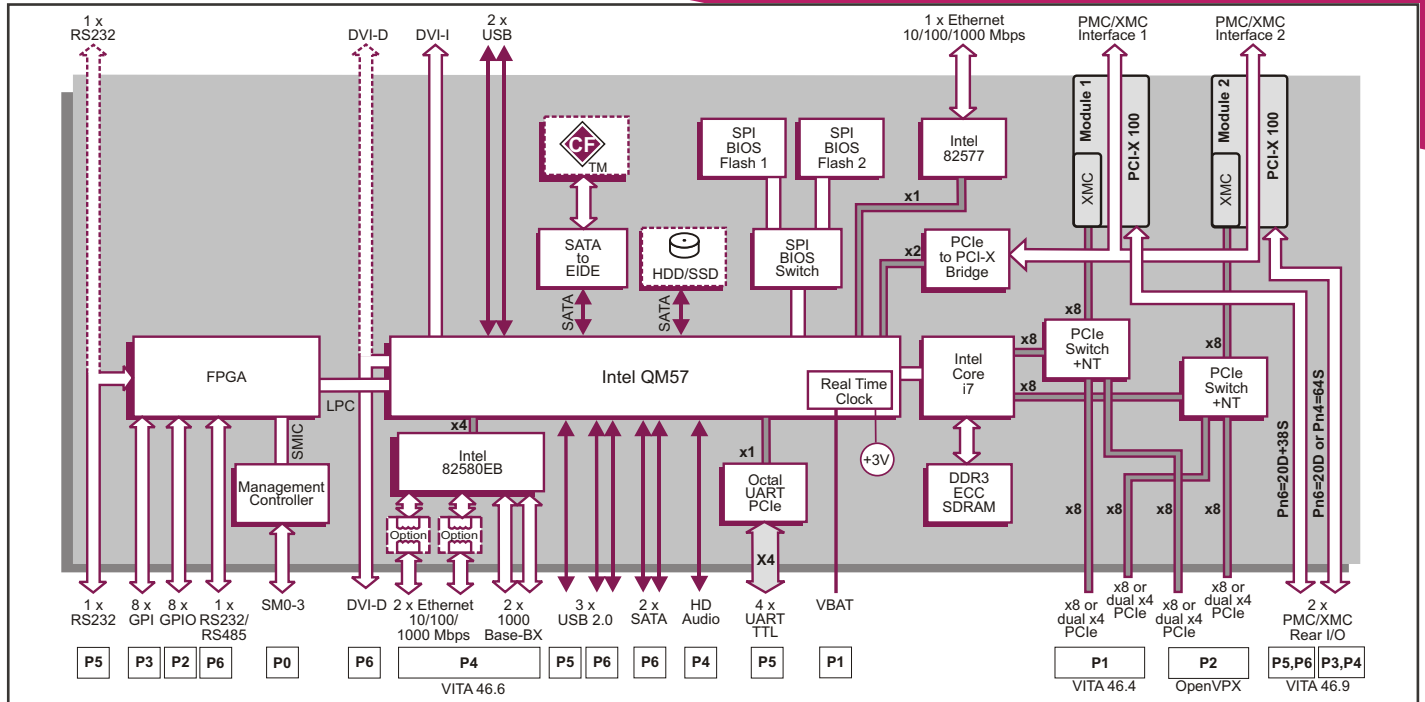

## Central Processor

- 2.53 GHz Intel® Core™ i7-610E processor, 2.0 GHz Intel® Core™ i7-620LE processor or 1.33 GHz Intel® Core™ i7-660UE processor
- common processor features are:-
  - dual-core processor
  - 4 Mbytes shared last level cache
  - Intel® Hyper-Threading Technology
  - Intel® 64 Technology (64-bit computing)
  - Intel® Turbo Boost technology
- processor to DRAM memory, bus speed:-
  - 610E and 620LE - 1066MHz; 660UE - 800MHz
- Intel Turbo Boost technology allows faster graphics engine speed depending on the CPU loading
- utilizes Intel® Platform Controller Hub (PCH):-
  - Mobile Intel® QM57 Express chipset
- supports up to 8 Gbytes DDR3-1066 ECC SDRAM:-
  - up to 8 Gbytes soldered
  - dual channel architecture
  - accessible from processor or VPX fabric

## PMC/XMC Interfaces

- 2 x PMC/XMC shared sites:-
  - front panel I/O
  - PMC sites support 32/64-bit, 33/66/100MHz PCI/PCI-X (3.3V PCI signaling, 5V tolerant)
  - XMC sites support x8 PCI Express® Gen 2 links
  - XMC sites powered from 5V supply
- Site 1 I/O via XMC Pn6 (VITA 46.9):-
  - 20 differential-pairs plus 38 single-ended
  - P5w3-X38s+P6w1-X12d+X8d
- Site 2 I/O via PMC Pn4 or via XMC Pn6 (VITA 46.9):-
  - option XMC Pn6, 20 diff-pairs, P4w1-X12d+X8d
  - option PMC Pn4, 64 single-ended, P3w1-P64s

## Mass Storage Interfaces

- 2 x SATA300 interfaces via P6
- support for on-board CompactFlash™ socket
- optional on-board 2.5-inch SATA300 hard-disk drive (HDD) or solid-state drive (SSD)

## Stereo Audio

- Intel® High Definition Audio

## Graphics Interfaces

- DVI-I interface on the front panel:-
  - digital up to 1600 x 1200 @ 16M colors
  - analog up to 1920 x 1200 @ 16M colors
- independent DVI-D interface on front panel:-
  - up to 1600 x 1200 @ 16M colors
  - can be switched from front panel to P6
- implemented by Intel® QM57 Express chipset

## Ethernet Interfaces

- one front panel 10/100/1000 Mbps Ethernet:-
  - implemented by Intel® 82577 LAN Controller
- 2 x 10/100/1000 Mbps Ethernet interfaces and 2 x 1000Base-BX interfaces via P4 (VITA 46.6):-
  - implemented by Intel® 82580EB LAN Controller
  - Ethernet option, with or without magnetics

## Serial Interfaces

- 1 x RS-232/422/485 channel via P6:-
  - supporting full modem in RS232 only
  - supporting Transmit Control in RS485 mode
- 1 x RS232 channel via front panel:-
  - can be switched from front panel to P5
- 4 x UART serial TTL interfaces via P5
- 16550 compatible UARTs

## VPX Backplane Interface

- configurable PCI Express® (PCIe) fabric:-
  - four x8 or eight x4 PCIe (PCIe Gen1 and Gen2)
  - compatible with OpenVPX™ module profiles
- supports up to four transparent/non-transparent links with DMA for multi-processing applications

## Other Peripheral Interfaces

- PC Real Time Clock
- long duration timer; watchdog timer
- CPU temperature and voltage sensors, accessed via System Management interface
- 3 x USB 2.0 interfaces, two via P6 and one via P5
- 2 x USB 2.0 interfaces accessed via front panel
- 8 x GPIO signals via P2 and 8 x GPI signals via P3

## Software Support

- support for Linux®, Windows® 7, Windows® Embedded Standard 7, Windows® XP, Windows® XP Embedded, Windows® Server 2003, Windows® Server 2008, VxWorks®, QNX®, Solaris™, LynxOS®

## Flash EPROM

- 8 Mbytes of BIOS Flash EPROM, dual devices:-
  - main/back-up device enabled via a switch

## Firmware Support

- UEFI-compliant BIOS, legacy mode support
- comprehensive Power-On Self-Test (POST)
- optional BIT (Build-In-Test):-
  - supporting PBIT, IBIT, CBIT
- LAN boot firmware included

## Safety

- PCB (PWB) manufactured with flammability rating of 94V-0

## System Management

- System Management interface:-
  - implements SMIO-1 and SMIO-3 hardware
- on-board System Management Controller

## Electrical Specification

- typical current figures (2.0GHz, 4 Gbytes SDRAM):-
  - VS3, +5V @ 10.5A, voltage +5% / -2.5%
  - AUX, +3.3V @ < 100mA, voltage +5% / -2%

## Environmental Specification

- operating temperature:-
  - VITA 47 Class AC1, 0°C to +55°C
  - air-cooled
  - up to 2.53 GHz Intel Core i7 processor
- storage temperature:-
  - VITA 47 Class C1, -40°C to +85°C
- operating altitude:
  - 0 to 15,000 feet (0 to 4,572 meters)
- 5% to 95% Relative Humidity, non condensing

## Mechanical Specification

- 6U VPX form-factor (VITA 46.0)
- 9.2 inches x 6.3 inches (233mm x 160mm)
- slot width (VITA 46.0):-
  - 0.8 inches
- connectors to VITA 46.0, P0 through to P6
- operating mechanical:-
  - shock - VITA 47 Class OS1, 20g
  - vibration - 0.002g<sup>2</sup>/Hz

## ORDERING INFORMATION

Order Number	Product Description (Hardware)
VR 737/08x-xy	Core i7 processor, 6U VPX, N-Series

For the order number suffix (xy) options please contact your local sales office:  
 where x = XMC/PMC I/O; Ethernet Magnetics where y = SDRAM size  
 x - XMC Pn6 or PMC Pn4; with/without magnetics y - up to 8 Gbytes SDRAM

For accessories please contact your local sales office. For ordering information please contact your local sales office.