

Intel® Core™ 2 Duo Processor, 3U SBC, Rugged Air-Cooled



APPLICATIONS

The TP 402/351-RC is a PC-compatible high performance, high functionality, ruggedized 3U CompactPCI® board supporting the 1.5 GHz Intel® Core™ 2 Duo processor L7400. It utilizes the Intel 3100 embedded server chipset to support up to 4 Gbytes of soldered DDR2 ECC SDRAM. This single slot board features a variety of interfaces including dual Serial ATA150, dual Gigabit Ethernet, RS232/422 and USB. The TP 402/351-RA is a ruggedized air-cooled board operating in temperatures

ranging from -40°C to +75°C, where it is suitable for a range of demanding applications within the defense, industrial control, telecomms, telemetry, transportation, scientific and aerospace markets. Ruggedized conduction-cooled or non-ruggedized air-cooled versions are also available. To simplify the board's integration many popular industry standard operating systems are supported.

HIGHLIGHTS

- Ruggedized 3U single board computer:
 - -40°C to +75°C operating temperature
 - ruggedized air-cooled
 - conformally coated
- 1.5 GHz Intel® Core™ 2 Duo processor:
 - 64 Kbytes L1 cache
 - 4 Mbytes L2 cache
 - Intel® 64 Technology (64-bit computing support)
 - low power processor
- 2 or 4 Gbytes of soldered DDR2-400 registered ECC SDRAM
- 2 x 10/100/1000Mbps Ethernet interfaces accessed via J2
- 5 x Serial ATA150 channels:
 - 2 x channels accessed via J2
 - 1 x channel for on-board Flash disk
 - 2 x channels routed to optional Flash Disk Module
- 2 serial channel interfaces accessed via J2
- 2 x USB 2.0 interfaces accessed via J2
- CompactPCI controller:
 - operates in the system slot or in a peripheral slot
 - 32-bit at 33/66 MHz CompactPCI interface
- Option to bypass CompactPCI bus (Satellite Mode)
- Watchdog and long duration timer
- Option for graphics on separate PMC card:
 - graphics PMC mounted on single slot 3U PMC carrier
 - analog and digital graphics via front panel and via PMC rear I/O
 - ruggedized or non-ruggedized versions
- Ruggedized conduction-cooled version (RC-Series) also available:
 - conduction-cooled to ANSI/VITA 30.1-2002
 - -40°C to +85°C
 - conformally coated
 - see separate TP 402/351-RC datasheet
- Non-ruggedized air-cooled versions also available:
 - rear plug compatible with the ruggedized version
 - useful for bench development
 - use in commercial (non-rugged) applications
 - see separate TP 402/351 datasheet
- Support for Linux®, Windows® XP, Windows® XP Embedded, Windows® Server 2003, Windows® 2000, QNX®, LynxOS® and VxWorks®

Ruggedized Single Board Computer

- conformally coated
- ruggedized air-cooled
- ruggedized conduction-cooled version also available:-
→ see TP 402/351-RC datasheet
- non-rugged version also available:-
→ see TP 402/351 datasheet

Central Processor

- 1.5 GHz Intel® Core™ 2 Duo processor L7400:-
→ using a µFC-BGA 478 (micro Flip-Chip Ball Grid Array) package
→ 64 Kbytes of primary (L1) on-die cache
→ 4 Mbytes of shared secondary (L2) on-die cache
→ 667 MHz Front Side Bus (FSB)
- Intel® 64 Technology (64-bit computing)
- utilizes 64-bit Intel® 3100 server chipset:-
→ single chip chipset with integrated memory and I/O controllers
- provision for ITP debug port

DRAM

- 2 or 4 Gbytes soldered DDR2-400 registered ECC SDRAM using:-
→ single channel memory
→ single-bit error correction
→ peak bandwidth of up to 3.2 Gbytes/s
- accessible from processor or CompactPCI® bus

Hard/Flash Disk Interfaces

- 5 x Serial ATA150 interfaces:-
→ transfer rate up to 150 Mbytes/s
- 2 x channels accessible via J2
- 1 x channel routed to on-board 512 Mbytes Flash disk
- 2 x channels routed to optional Flash Disk Module:-
→ one or two Flash disk drives
→ appear as one or two hard disk drives
→ uses XMC connectors (see Note 1)

Ethernet Interfaces

- 2 x channels supporting:-
→ 10 Base-T, 100 Base-TX, 1000 Base-T
→ implemented by Intel® 82571EB via x4 PCI Express® port
→ both channels accessed via J2

Optional Graphics Interface

- optional ruggedized PMC card mounted on ruggedized 3U CompactPCI PMC carrier:-
→ see separate IO PMC/722-RA and TP CRx/PMC-RA datasheets
- for IO PMC/722-RA:-
→ implemented by Silicon Motion SM722
→ analog and digital graphics accessed via front panel DVI-I connector or PMC rear I/O
→ 8 Mbytes video memory
→ resolutions up to 1280 x 1024; supporting up to 16M colors

Serial Interfaces

- 2 serial interfaces accessible via J2
- 1 x RS232 interface supporting Tx and Rx
- 1 x RS232 interface supporting Tx, Rx, RI, CTS, RTS, DSR, DTR and DCD or 1 x RS422/485 supporting Tx and Rx
- 16550 compatible UARTs

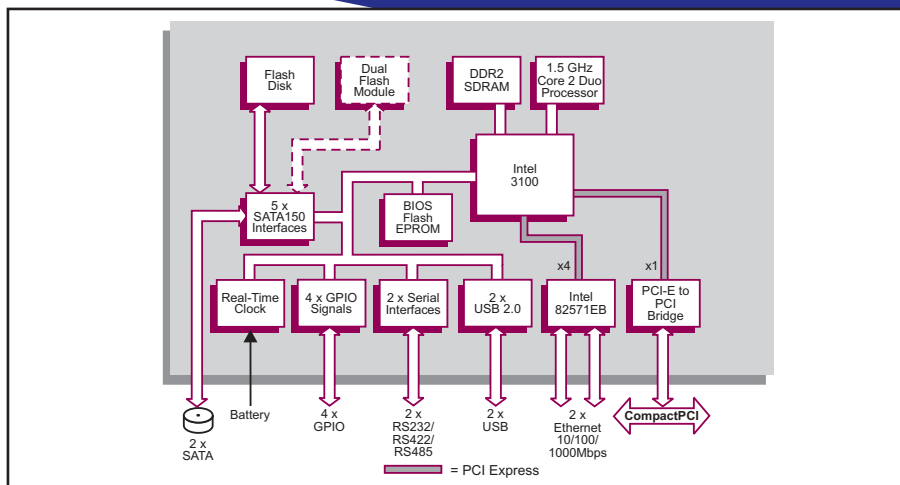

Flash EPROM

- 1 Mbyte of BIOS Flash EPROM
- hardware write protect provided

Other Peripheral Interfaces

- PC-compatible Real Time Clock (Year 2000 compliant)
- long duration timer
- watchdog timer
- legacy speaker interface
- 2 x USB 2.0 interfaces:-
→ both accessed via J2
- external battery supply for RTC and BIOS data
- 4 x GPIO signals via J2
- on-board I°C bus used for local temperature and power supply sensors, accessible via J1

CompactPCI Interface

- universal signaling support, compliant with PICMG 2.0 R3.0; 3.3V or 5V signaling levels
- 33/66 MHz; 32-bit interface accessed via J1
- utilizing a PCI Express-PCI bridge for off-board accesses
- operates as a System Slot controller (supporting up to 7 peripheral slots) or operates in a Peripheral Slot:-
→ supports hot-swapping peripheral boards
→ PICMG 2.1 R2.0 Hot Swap Specification
- option to disable CompactPCI interface (Satellite Mode):-
→ receives power from CompactPCI bus
→ board can be hot swapped

Firmware Support

- Phoenix™ TrustedCore BIOS
- Trusted Platform Module (TPM) support
- comprehensive Power-On Self-Test (POST)
- LAN boot firmware included

Software Support

- supports Linux®, Windows® XP, Windows® XP Embedded, Windows® 2000, Windows® Server 2003, QNX®, LynxOS® and VxWorks®

Electrical Specification

- +5V@TBD A
- +3.3V@TBD A
- +12V and -12V not required
- all voltages are tolerant to ±5%

Safety

- PCB (PWB) manufactured with flammability rating of 94V-0

Environmental Specification

- ruggedized operating temperatures:-
→ -40°C to +75°C (air-cooled)
- storage temperature: -40°C to +100°C
- 5% to 95% Relative Humidity, non condensing (operating or storage):-
→ conformally coated
- altitude (operating):
-1,000 to 33,000 feet (-305 to 10,058 meters)
- non-ruggedized wide temperature versions available:
→ see separate TP 402/351 datasheet

Mechanical Specification

- 3U form-factor: 3.9 inches x 6.3 inches (100mm x 160mm)
- single slot
- connectors: IEC-1076-4-101 for J1-J2
- shock:
40g, 11ms, ½ sine (operating)
- sine vibration:
5Hz-2000Hz at 3g, peak (operating)
- random vibration:
0.04 g²/Hz (10Hz-1KHz);
-6dB/octave (1KHz-2KHz) (operating)
- rear plug compatible with commercial non-ruggedized TP 402/351:-
→ see separate TP 402/351 datasheet
- rear plug compatible with ruggedized conduction-cooled TP 402/351-RC:-
→ see separate TP 402/351-RC datasheet

Note 1: The XMC connectors are provided for the SATA Flash Disk Module only. The CPU heatsink for air-cooled boards does not allow an XMC module. The conduction-cooled board does support an optional XMC module (see separate TP 402/351-RC datasheet).

ORDERING INFORMATION

Order Number	Product Description (Hardware)
TP 402/351-1yRA	1.5 GHz Core 2 Duo processor L7400 ruggedized air-cooled
AD 250/001-zz	Single drive SATA Flash Disk Module
AD 250/002-zz	Dual drive SATA Flash Disk Module

Replace the order number suffix (y) with selections from the following:

- where y =
- 1 - reserved
 - 2 - reserved
 - 3 - 2 Gbytes
 - 4 - 4 Gbytes

For z options please contact your local sales office

For ruggedized conduction-cooled version, see separate TP 402/351-RC datasheet
For non-rugged version, see separate TP 402/351 datasheet