

PMC Carrier Board



APPLICATIONS

The AD CR2/PMC Carrier Board can be used with several of Concurrent Technologies' range of VME PMC host processor boards. The carrier board allows 2 PMC modules to be added to the host processor board, thereby increasing the flexibility and functionality of the host

board. Standard PMC slave boards include SCSI, LAN, WANs, Graphics, Communications and Modems. Non-monarch processor PMCs (PrPMC) can also be used. Specialized I/O can be designed and added using the AD CR2/PMC Carrier Board.

HIGHLIGHTS

- Supports 2 single size PMC modules or 1 double size module
- I/O via front panel and P2 backplane connector and optional P0 backplane connector
- Up to 128 rear panel I/O lines
- 5V and 3.3V PMC modules supported
- For use with selected Concurrent Technologies VME PMC host processor boards
- Occupies one VME slot
- Standard PCI bus expansion using PCI-PCI bridge, compatible with, for example:
 - VxWorks®
 - Windows® 2000
 - Linux®
- Operating system depends on the Concurrent Technologies PMC host processor board

PMC Interfaces

- 2 interfaces provided:-
 - each supports a single size (75mm x 150mm) PMC module
- I/O is accessible via:-
 - front panel; and/or,
 - P2 backplane connector; and/or,
 - P0 backplane connector (optional)
- 64 I/O signals via P0 connector
- 64 or 32+32 I/O signals via P2 connector
- complies with CMC (Common Mezzanine Card) standard (IEEE P1386)
- I/O pin mapping compliant with ANSI/VITA 35-2000 PMC I/O wiring standards
- I/O user configurable with jumper blocks
- logical layer based on PCI protocol specification
- electrical layer based on PCI electrical specification
- supports 5V or 3.3V PMC modules
- provides 3.3V supply

Adapter Interface

- connects to a VME PMC host processor board
- utilizes PCI electrical specification
- utilizes PCI logical layer specification

Compatible PMC Host Boards

- Example host processor boards are:-
 - VP 317/02x
 - VP 315/02x
 - VP 307/01x
 - VP 305/01x
 - VP 110/01x
 - VP 101/01x

Software Support

- adapter features a standard PCI-PCI bridge:-
 - PMC modules appear on the additional PCI bus
- compatible with various operating systems, for example VxWorks, Windows 2000 or Linux

Electrical Specification

- all voltages to be within $\pm 5\%$
- power taken from VME bus P1 connector
- 0.5A (maximum) current consumption at +5V
- 0.0A current consumption at +12V
- 0.0A current consumption at -12V

Environmental Specification

- compatible with PMC host boards operating at:-
 - -0°C to +55°C (N-Series)
 - -25°C to +70°C (E-Series)
- 10% to 90% Relative Humidity non-condensing (operating)
- -40°C to +70°C (storage)
- 10% to 90% Relative Humidity non-condensing (storage)

Mechanical Specification

- utilizes a single VME slot
- has a VME front panel:-
 - VME 6U dimensions
- shock:
 - 20g, 11ms, 1/2 sine (operating);
 - 30g, 11ms, 1/2 sine (non-operating)
- vibration:
 - 5Hz-2000Hz at 2g, 0.38mm peak displacement (operating);
 - 5Hz-2000Hz at 5g, 0.76mm peak displacement (non-operating)

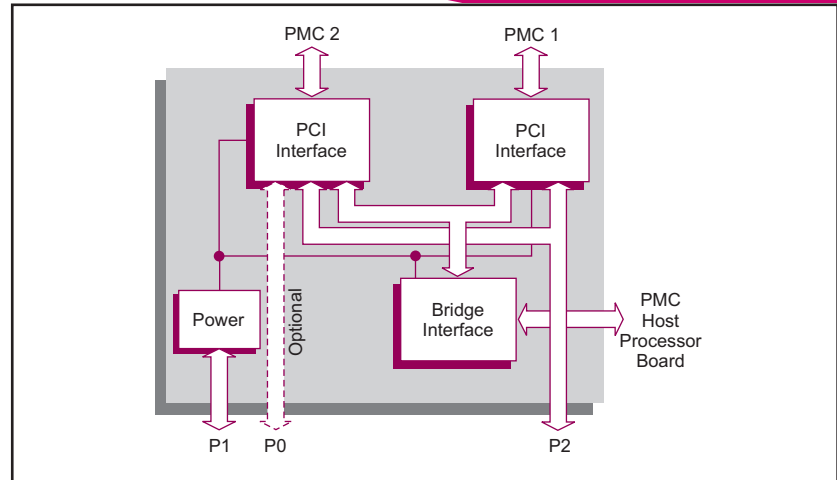

ORDERING INFORMATION

Order Number Product Description (Hardware)

- AD CR2/PMC-00 PMC Carrier Board without P0 Connector
- AD CR2/PMC-01 PMC Carrier Board with P0 Connector and with VME64x handles
- AD CR2/PMC-10 PMC Carrier Board without P0 Connector and with VME64x handles