

Quad Port 10/100/1000 Ethernet XMC Adaptor

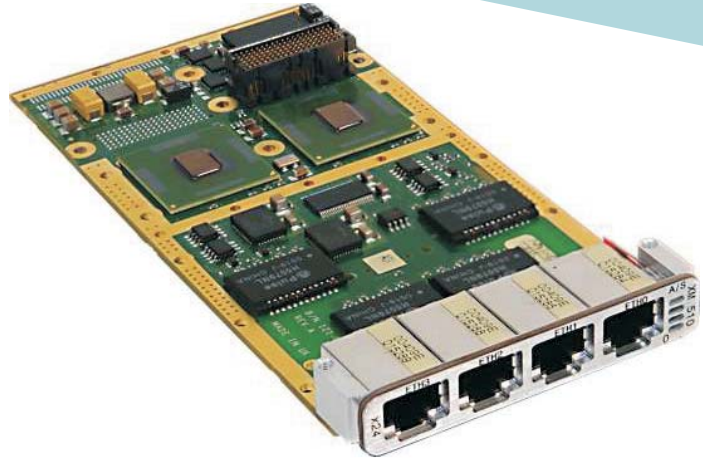

APPLICATIONS

The XM 510/x24 is a high performance, quad Gigabit copper interface Ethernet adaptor suitable for use with XMC Host Boards including VME and CompactPCI®. The board is designed for applications that require high-speed data throughput and lower-latency communications, such as high-speed image transfer, fast industrial control operations and

telecommunications. For harsher environments, extended temperature, ruggedized air-cooled and ruggedized conduction-cooled versions will also be available.

HIGHLIGHTS

- 4 x high performance Gigabit Ethernet interfaces:
 - 10Base-T/100Base-Tx/1000Base-T
 - RJ45 connectors
 - 1000Mbps with CAT5/5e cabling
 - speed and status indicators
- XMC (Switched Mezzanine Card) format:
 - single size CMC (Common Mezzanine Card)
 - up to x4 PCI Express® interface
- Front or rear I/O
- Extended temperature version available:
 - -25°C to +70°C (E-Series)
 - -40°C to +85°C (K-Series, includes humidity sealant)
- For use with VME, CompactPCI® and other XMC Host Boards
- Ruggedized air-cooled version (RA-Series):
 - -40°C to +75°C, conformally coated
- Ruggedized conduction-cooled version (RC-Series):
 - conduction-cooled
 - -40°C to +85°C, conformally coated
- Software support for Linux®, VxWorks®, Windows® 2000, Windows® XP, Windows® XP Embedded and QNX®

Gigabit Ethernet Interfaces

- 4 x 1000Base-T/100Base-Tx/10Base-T
- factory build options for:-
 - 4 x Ethernet via PMC P4 or XMC P6 connector or
 - 4 x RJ45 connectors on front panel
- implemented by 2 x Intel® 82575EB Gigabit Ethernet controllers:-
 - supports IEEE 802.3ab for 1000Base-T over Category 5/5e UTP (Unshielded Twisted Pair) Cable
 - supports IEEE 802.3/802.3u for 10Base-T/100Base-Tx over Category 5 UTP cable
 - supports Jumbo frames
- individual MAC and frame Controllers supporting the following features:-
 - 8 Kbyte transmit and receive FIFOs for each port
 - 48 Kbyte per-port packet buffer
 - transmit and receive IP, TCP and UDP checksum off-loading
 - transmit TCP segmentation
 - automatic retransmission
 - automatic receive stripping and transmit padding (individually programmable)
 - automatic runt frame rejection
- physical interfaces (PHY) implemented by the Intel 82575EB devices internally supporting:-
 - 1000Base-T/100Base-Tx/10Base-T auto-negotiation
 - automatic polarity and MDI/MDI-X selection
 - full and half duplex operation
- status LEDs, front or rear (none on PMC rear I/O variants)

XMC Interface

- complies with PCI Express Protocol Specification 2.0 including:-
 - x4 PCI Express® interface
 - trains down to x2 or x1
- PCI Express switch provides expansion from single x4 port to 2 x4 ports connecting to the Ethernet controllers

BIOS EPROM

- 8-bit wide 128 Kbyte SPI Flash EPROM with PXE BIOS Firmware:-
 - one per Ethernet controller
- in-circuit programmable

Software

- support for Linux®, VxWorks®, Windows® 2000, Windows® XP, Windows® XP Embedded and QNX®

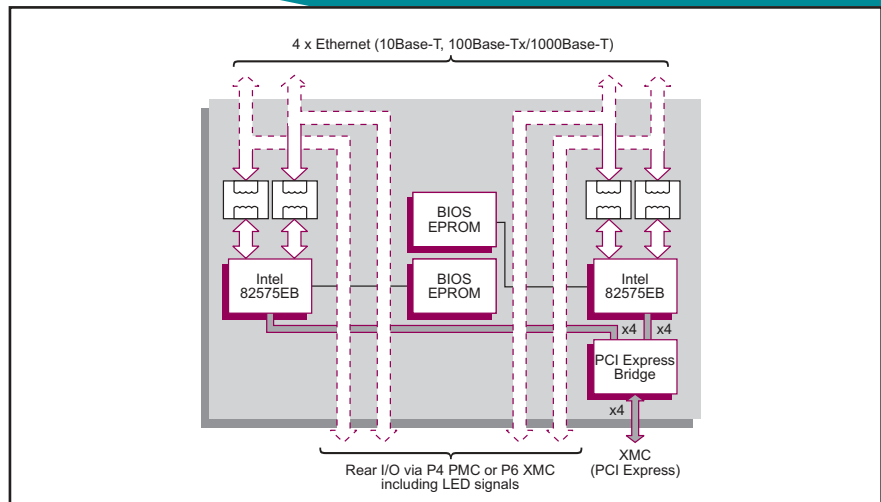

Electrical Specification

- +5V@TBD A or +12V@TBD A (typical with quad 1000Base-T operating); ±5%
- 3.3V and -12V not utilized

Environmental Specification

- compatible with XMC host boards operating at:-
 - 0°C to +55°C (N-Series)
 - -25°C to +70°C (E-Series)
 - -40°C to +85°C (K-Series)
- 5% to 95% Relative Humidity, non-condensing (operating):-
 - K-Series includes humidity sealant
- -40°C to +85°C (storage)
- 5% to 95% Relative Humidity, non-condensing (storage)
- ruggedized air-cooled and ruggedized conduction-cooled versions planned

Mechanical Specification

- single size CMC (Common Mezzanine Card) 74mm x 149mm
- 10mm height stack module

ORDERING INFORMATION

Order Number Product Description (Hardware)

Order Number	Product Description (Hardware)
XM 510/024-10	Quad Port Gig Ethernet XMC Adaptor, 4 x front panel RJ45 connectors
XM 510/124-30	Quad Port Gig Ethernet XMC Adaptor, 4 x rear panel outputs (with Ethernet magnetics) via XMC P6 rear I/O connector
XM 510/124-31	Quad Port Gig Ethernet XMC Adaptor, 4 x rear panel outputs (without Ethernet magnetics) via XMC P6 rear I/O connector
XM 510/224-30	Quad Port Gig Ethernet XMC Adaptor, 4 x rear panel outputs (with Ethernet magnetics) via PMC P4 rear I/O connector
XM 510/224-31	Quad Port Gig Ethernet XMC Adaptor, 4 x rear panel outputs (without Ethernet magnetics) via PMC P4 rear I/O connector

For extended temperature E and K-Series, please contact your local sales office
 For ruggedized versions, see separate datasheets: XM 510/x24-RC (conduction-cooled) or XM 510/x24-RA (air-cooled)